

REVISIONS						
SHEET	ZONE	REV.	ECO	DESCRIPTION	DATE	APPROVED
1	ALL	A	CORRECTED PART NUMBER ON TITLE BLOCK	10/14/2011	HRC
1	ALL	B	CORRECTED LATCH P/N ON BOM	11/16/2011	HRC
1	ALL	C	50253	UPDATE DWG TO CURRENT FORMAT & STANDARDS	10/30/2018	HRC

**LATCH HARDWARE
(STAINLESS STEEL)**

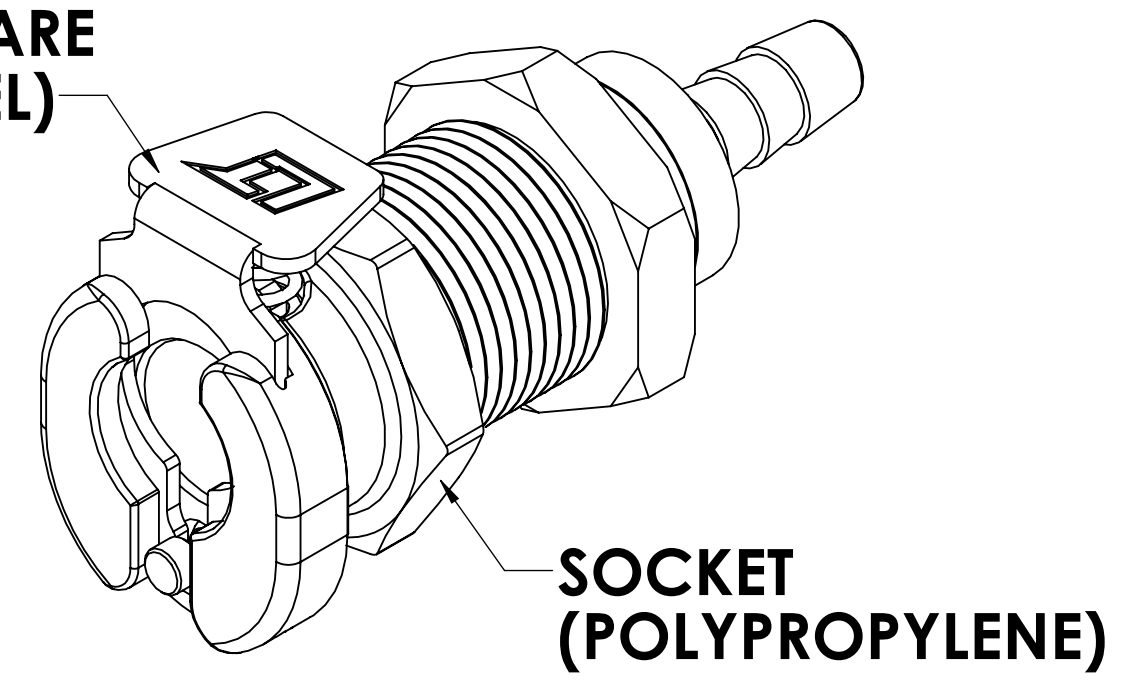

**SOCKET
(POLYPROPYLENE)**

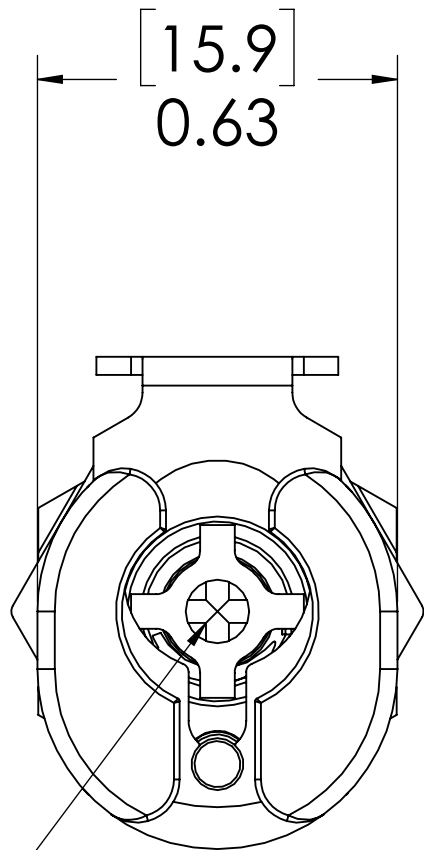

**VALVE
(POLYPROPYLENE)**

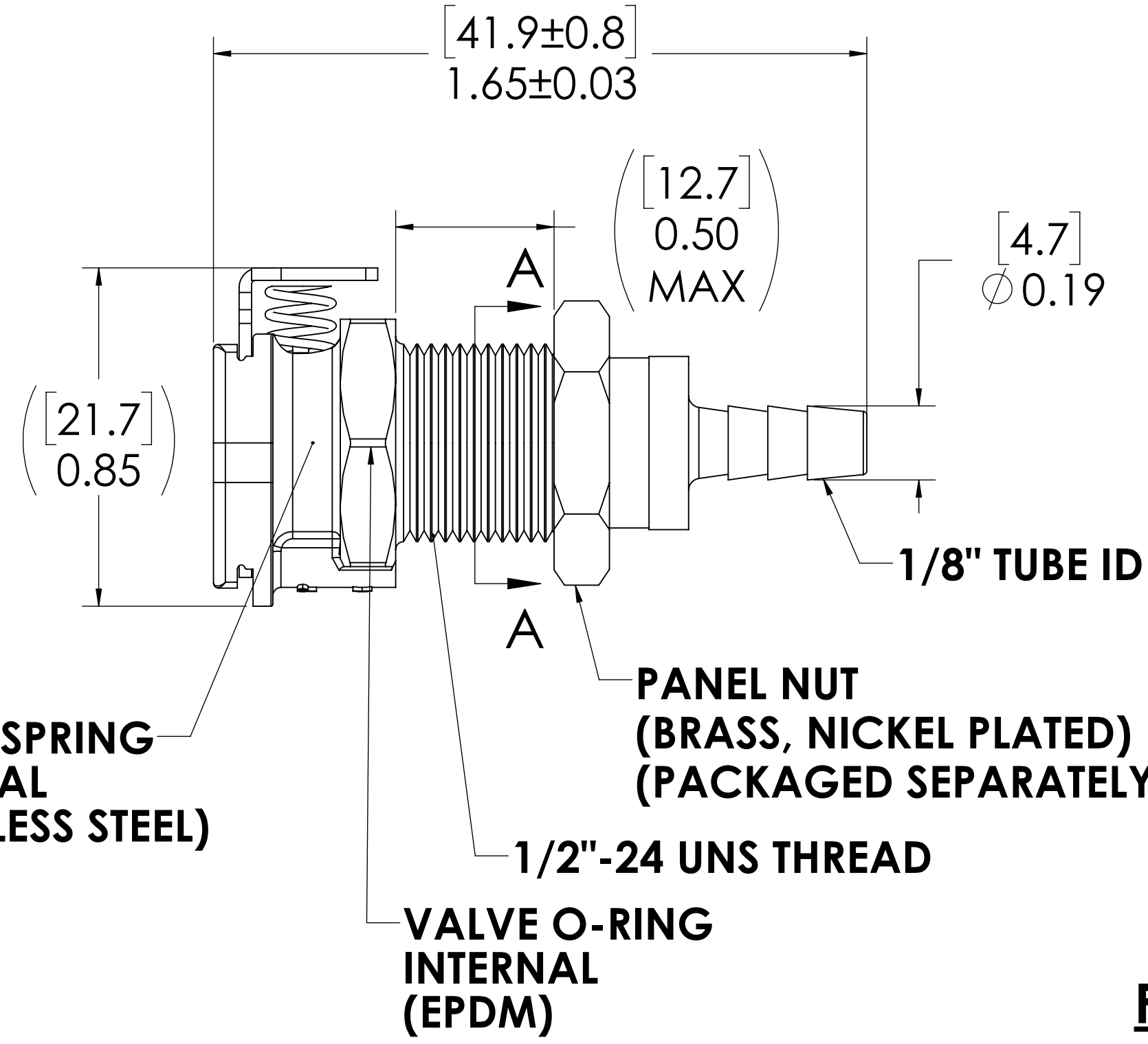

**VALVE SPRING
INTERNAL
(STAINLESS STEEL)**

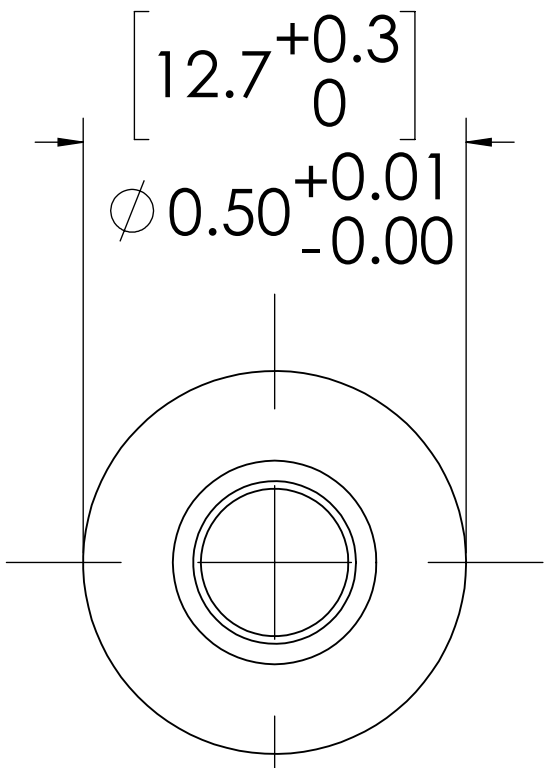

**PANEL OPENING
(SECTION A-A)**

NOTES:

- MATERIAL: POLYPROPYLENE
- COLOR: GREY
- O-RING MATERIAL: EPDM
- O-RINGS LUBRICATED WITH FOOD GRADE SILICONE OIL, 350 CST.

FOR REFERENCE ONLY

<small>UNLESS OTHERWISE SPECIFIED: DIMENSIONS ARE IN INCHES TOLERANCES: FRACTIONAL ± 1/32 ANGULAR: MACH ± 0.5 BEND ± 2 ONE PLACE DECIMAL ± 0.1 TWO PLACE DECIMAL ± 0.01 THREE PLACE DECIMAL ± 0.005 TWO PLACE DUAL (mm) [± 0.12]</small>	DRAWN	LMP	6/7/2018	
	CHECKED	HRC	6/7/2018	
	ENG APPR.	HRC	10/30/18	
	MFG APPR.	BDB	10/30/18	
<small>PROPRIETARY AND CONFIDENTIAL THE INFORMATION CONTAINED IN THIS DRAWING IS THE SOLE PROPERTY OF LINKTECH LLC. ANY REPRODUCTION OR DISCLOSURE IN PART OR AS A WHOLE WITHOUT THE WRITTEN PERMISSION OF LINKTECH LLC IS STRICTLY PROHIBITED.</small>	PURCHASING	LS	10/30/18	PART NO: 20PPV-SE3-02 DESCRIPTION: LinkTech 20PP Series Panel Mt. Female, Valved, 1/8" HB, Polypropylene
SIZE DWG. NO. C 20PP200086		REV C	SCALE: NTS WEIGHT: SHEET 1 OF 1	